

**CROSBY JB AND JPV-A**  
LARGE ORIFICE PRESSURE RELIEF VALVE

Engineered to provide high quality, dependable overpressure protection for air, gas, vapor and steam applications.

**Features and benefits**

- Broadest product offering in the industry.
- Ten sizes available.
- Reduced installation and labor costs (1 valve versus multiple smaller valves).
- Fewer discharge lines.
- Fewer inlet connections.
- Reduced maintenance costs.
- Fatigue resistant bellows material.

**Applications**

- Turbine exhaust lines
- Main steam lines to process plants
- Low pressure gas service in refineries
- Polyvinyl chloride reactors
- Deaerators
- Oil refinery coke drums
- Beet sugar plant evaporators
- Moisture separator reheaters in nuclear power plants

**Technical data**

Sizes: 10" V 14" to 20" BB<sub>2</sub> 24"  
Orifices: V to BB<sub>2</sub>  
Inlet Rating: 300 lbs. ANSI  
Temperature Range: -20°F to +450°F

# CROSBY JB AND JPV-A

## LARGE ORIFICE PRESSURE RELIEF VALVE

### Introduction

Crosby large orifice pressure relief valves were originally developed in response to the growing size of commercial power plants and resultant increased generating capacities.

Traditionally, overpressure protection for large piping and vessels in power and process plants has been satisfied by multiple pressure relief valves. Style JB-TD large orifice relief valves were designed to eliminate the high costs of installation labor, inlet and discharge piping, maintenance and spare parts associated with the use of multiple,

smaller API Standard 526 pressure relief valves. The largest, with a relief capacity nearly seven times that of a T-orifice valve, can relieve approximately 3,000,000 pounds per hour of saturated steam at 300 psig set pressure.

These "Above T" orifice relief valves represent a low cost alternative. The large orifice relief valve product line is an extension of the traditional API Standard 526 JOS-E/JBS-E product line and provides the same dependability and reliable performance.

Crosby manufactures the broadest scope of large orifice relief valves ranging from 10 V 14 to 20 BB<sub>2</sub> 24 with actual orifice areas ranging from 47.85 square inches to 213.82 square inches.

Style JB-TD relief valves are manufactured in accordance with ASME Boiler and Pressure Vessel Code, Section VIII and their air and steam capacities are certified by the National Board of Boiler and Pressure Vessel Inspectors (UV and NB).

### Operation

Construction of the Style JB relief valve is somewhat different than the API Standard 526 Style JBS-E design. The standard cast Body has a 300# ANSI flanged inlet as standard construction and a 150# ANSI flanged outlet. The inlet and outlet flanges are integrally cast with the valve Body.

The large diameter Nozzle (2) is threaded into the Body and seal welded. To help ensure tight shutoff, the Disc Insert (6) is free to float within the Disc Holder (20) providing uniform seat contact with the Nozzle seating surface.

Low friction guiding is provided by a Bearnium B10 Disc Holder Sleeve (21) and a Bearnium B10 Spindle Guide Sleeve (28).

The Nozzle, Disc Insert, Disc Holder, Nozzle Ring (3) and Disc Ring (25) are manufactured from 300 Series stainless steel. The Bellows (23) is manufactured from fatigue-resistant Inconel<sup>®</sup> alloy 625.

The Bellows Protector (24), Bellows and Disc Holder are one assembly. A large,

non-adjustable Disc Ring is pinned to the Disc Holder. The effective area of the Bellows is designed to be the same as the area of the Disc Insert exposed to inlet pressure before the valve opens. The Bellows isolates the Bonnet from discharge back pressure and because of the equal areas mentioned, the valve set pressure is independent of back pressure.

In operation, system pressure increases until the static pressure acting against the disc generates an upward force equal to the downward force of the valve spring. When these two forces are in balance, the valve starts to simmer, which is the initial indication of valve opening. On vapor or gas service, the valve will open with a pop action. The first stage of lift is caused by the forces that are generated as the nozzle pressure reacts against the increased area of the secondary orifice, called the huddling chamber, which overhangs the disc. Full lift is developed by the dynamic forces of the stream flowing through the

conical nozzle. The velocity, the mass of the process fluid and the pressure-area relationship collectively keep the valve fully open. The valve will be relieving its full rated capacity when the pressure at the valve inlet has risen 10 percent above the set pressure of the valve.

As long as the inlet pressure continues to remain at or above the set pressure, the valve will remain open. When the inlet pressure diminishes, the flow forces diminish and the valve begins to close. At a pressure less than the set pressure, the spring force is sufficient to reseal the disc against the reduced flow force and the valve reseats.

**Standard Materials of Construction**

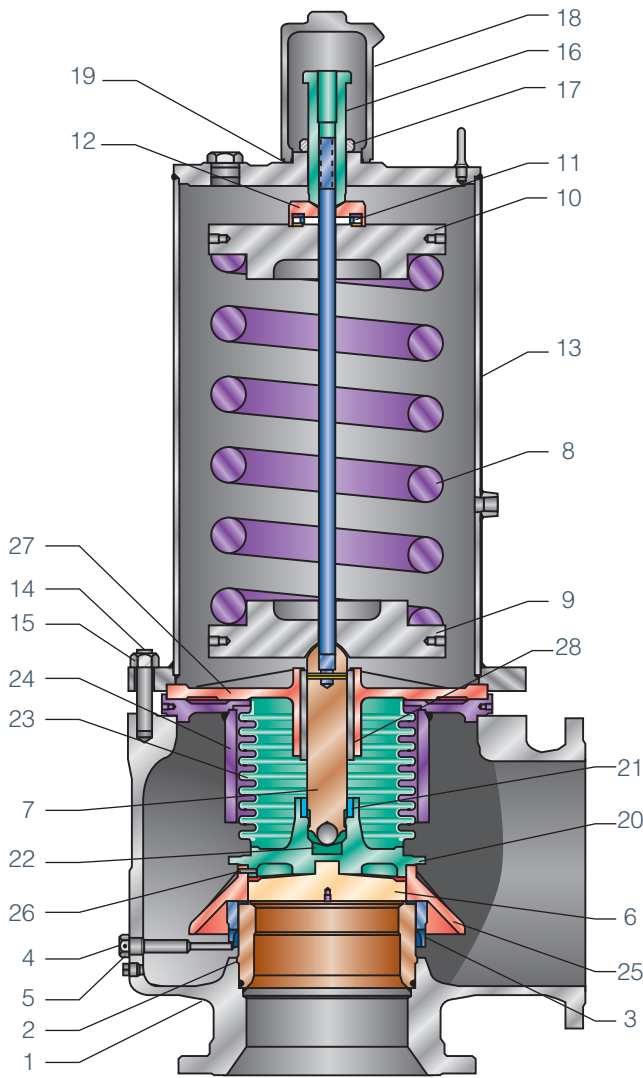

**Style JB**

Part No.	Part Name	Material
1	Body	ASME SA216 Gr. WCB Carbon Steel
2	Nozzle	ASME SA182 F316 Stainless Steel
3	Nozzle Ring	316 Stainless Steel
4	Set Screw	416 Stainless Steel
5	Set Screw Gasket <sup>2</sup>	Steel
6	Disc Insert <sup>2</sup>	ASME SA182 F316 Stainless Steel
7	Spindle <sup>1</sup>	416 Stainless Steel
8	Spring <sup>1, 4</sup>	Carbon Steel
9	Spring Washer (bottom) <sup>1</sup>	ASME SA216 Gr. WCB/ SA516 Gr. 70 Carbon Steel
10	Spring Washer (top) <sup>1</sup>	ASME SA216 Gr. WCB/ SA516 Gr. 70 Carbon Steel
11	Thrust Bearing <sup>3</sup>	Commercial
12	Thrust Bearing Adapter <sup>3</sup>	416 Stainless Steel
13	Bonnet Assembly	
	Top Flange	ASME SA216 Gr. WCB Carbon Steel
	Pipe	ASME SA285/SA106 Carbon Steel
	Thredolet	ASME SA105
	Bottom Flange	ASME SA181 Carbon Steel
14	Bonnet Stud	ASME SA193 Grade B7
15	Bonnet Stud Nut	ASME SA194 Grade 2H
16	Adjusting Bolt	416 Stainless Steel
17	Adjusting Bolt Nut	416 Stainless Steel
18	Cap (Type A)	Carbon Steel
19	Cap Gasket <sup>2</sup>	Steel
20	Disc Holder <sup>1</sup>	316/316L Stainless Steel
21	Disc Holder Sleeve <sup>1</sup>	Bearium B10
22	Disc Bushing <sup>1</sup>	Stainless Steel
23	Bellows <sup>1</sup>	Inconel® 625
24	Bellows Protector <sup>1</sup>	Carbon Steel
25	Disc Ring	300 Series Stainless Steel
26	Disc Ring Pin <sup>2</sup>	Stainless Steel
27	Spindle Guide <sup>1</sup>	Carbon Steel
28	Spindle Guide Sleeve <sup>1</sup>	Bearium B10

**Notes:**

1. Furnished as a sub-assembly only.
2. Recommended spare part.
3. Thrust bearing and adapter only used on "V" through "Z<sub>2</sub>" orifice valve with 100 psig set pressure or less.
4. Spring may be single or dual design (nested) depending on set pressure and valve design.

# CROSBY JB AND JPV-A

## LARGE ORIFICE PRESSURE RELIEF VALVE

### Caps and Lifting Lever

Crosby Style JB large orifice pressure relief valves are usually furnished with Type A threaded cap with gasket. The cap is sealed in place with a lead seal to prevent tampering with the adjusting bolt. If a test rod is provided, the Type A designation changes to Type B.

#### Lifting lever

Where desired, valves may be furnished with packed lifting lever. Such lifting lever is mandatory for air and steam service when the requirements of the ASME Boiler and Pressure Vessel Code, Section VIII (UV stamp) must be met.

Packed: Type D packed lifting lever is designed for service where tightness on the discharge side is necessary. The lifting lever linkage is sealed with O-rings or standard packing. The main working parts of the valve are as free to operate as with a standard valve. The packed lifting lever designation changes to Type E when a test rod is provided.

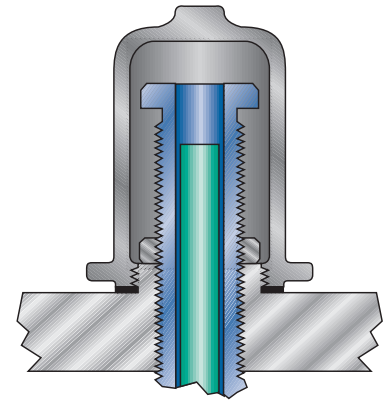

**Type A (standard)  
Threaded Cap**

Part No.	Part Name	Material
30	Lever	Steel
36	Spindle Nut	Steel
37	Spindle Nut Cotter Pin <sup>2</sup>	Steel
38	Cap Stud	ASME SA193 Gr. B7
39	Cap Stud Nut	ASME SA194 CL 2H
40	Dog	Steel
41	Dog Shaft	Stainless Steel
42	Dog Shaft Bearing <sup>1</sup>	Stainless Steel
43	Dog Shaft Bearing Gasket <sup>1,2</sup>	Steel
44	Dog Shaft Bearing O-ring <sup>1,2</sup>	Viton® - A
45	Cap Top	Steel
46	Cap Top Gasket <sup>2</sup>	Steel
47	Lever Nut <sup>1</sup>	Steel
48	Lock Washer <sup>1</sup>	Steel
49	Test Gag <sup>1</sup>	Steel
50	Test Rod Plug <sup>1</sup>	Steel
51	Test Rod Plug Gasket <sup>1,2</sup>	Steel

#### Notes:

1. Part not shown.
2. Recommended spare part.

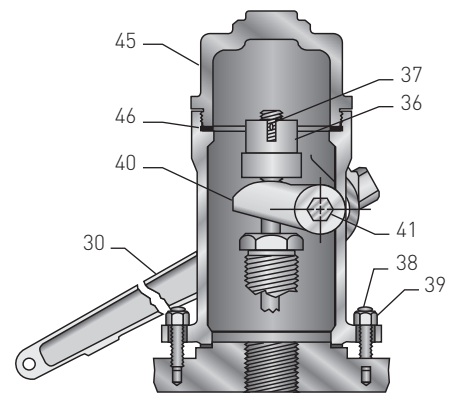

**Type D  
Packed Lifting Lever**

**CROSBY JB AND JPV-A**  
LARGE ORIFICE PRESSURE RELIEF VALVE

**Dimensions – Style JB**

Size	ASME Actual Orifice Area (sq.in)	Connections		Maximum Set Pressure <sup>4</sup> psig -20°F to 450°F <sup>2</sup>	Back Pressure Limit <sup>3</sup> @ 100°F (psig)	Dimensions (inches)						Approx. Weight (lbs)
		Inlet Flange <sup>1</sup> (ANSI)	Outlet Flange (ANSI)			E	P	G	H Type A & B Cap	H Type D & E Lifting Lever	X	
10 V 14	47.85	10" 300#	14" 150#	300	120	12	16	29	73	79	17/8	2250
12 W 16	68.90	12" 300#	16" 150#	300	175	14	16	30	77	83	2	2500
12 W <sub>1</sub> 16	72.00	12" 300#	16" 150#	300	175	14	16	30	77	83	2	2500
14 Y 18	93.78	14" 300#	18" 150#	300	175	16	20	37	85	93	2 1/8	4500
16 Z 18	103.15	16" 300#	18" 150#	300	175	16	20	37	85	93	2 1/4	5000
16 Z <sub>1</sub> 18	110.00	16" 300#	18" 150#	300	175	16	20	37	85	93	2 1/4	5000
16 Z <sub>2</sub> 20	123.47	16" 300#	20" 150#	300	175	17	21	39	90	98	2 1/4	5700
18 AA 24	155.04	18" 300#	24" 150#	300	175	20	25	48	103	108	2 3/8	6500
20 BB 24	191.38	20" 300#	24" 150#	300	175	20	25	48	103	108	2 1/2	7500
20 BB <sub>2</sub> 24	213.82	20" 300#	24" 150#	300	175	20	25	48	103	108	2 1/2	7500

**Notes:**

1. Optional Class 150# inlet flange available on application.
2. Optional materials of construction for temperatures above 450°F available on application.
3. Higher backpressure limits may be achievable on application. Consult your sales representative for more information.
4. May exceed 300 psig set pressure on application. Contact your sales representative.

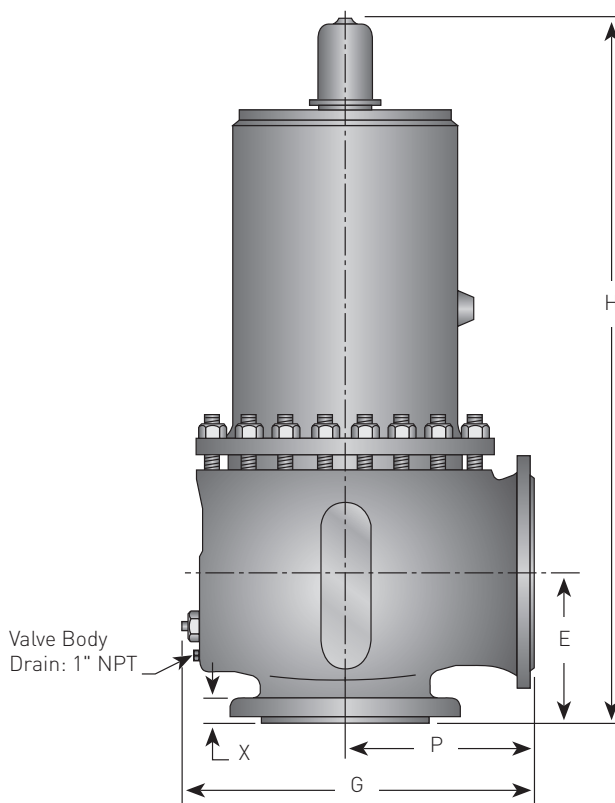

**Style Designations**

Size Inlet x Orifice x Outlet	Style	Pressure/Temperature Inlet Flange Range Ratings	Caps and Lifting Levers (Type)	Available Options
10 V 14 12 W 16 12 W <sub>1</sub> 16 14 Y 18 16 Z 18 16 Z <sub>1</sub> 18 16 Z <sub>2</sub> 20 18 AA 24 20 BB 24 20 BB <sub>2</sub> 24	JB-TD	26-3 ANSI Class 300# Inlet x 150# Outlet (Maximum Set Pressure 300 psig) -20°F to 450°F	Type A - Threaded Cap Type B - Threaded Cap with Test Rod Type D - Packed Lifting Lever Type E - Packed Lifting Lever with Test Rod	Set pressures below 25 psig Temperatures above 450°F Conventional (non-bellows) Inlet flange ratings above Class 300# Fully rated Class 300# outlet connection Open bonnet construction Full nozzle construction Class 150# inlet flange Special materials Non-destructive testing (LP, MP, etc.) Weatherhood

**CROSBY JB AND JPV-A**  
LARGE ORIFICE PRESSURE RELIEF VALVE

**Air Capacities, USCS Units – Style JB**

**Capacity Formula**

$W = 18.331 * A * P * K$

where

W = Rated capacity in SCFM

A = Nozzle throat (orifice) area, sq. in.

P = Flowing pressure in absolute pressure, psia: = (Set Pressure x 1.10) + 14.7 or (Set Pressure + 3) + 14.7, whichever is higher

K = Average coefficient of discharge  
= 0.856 for orifices V thru BB  
= 0.840 for BB2

Capacity in standard cubic feet per minute of Air at 60°F and 10 percent overpressure. Valve discharging to atmospheric pressure. Capacities certified by the National Board of Boiler and Pressure Vessel Inspectors and in accordance with the ASME Boiler and Pressure Vessel Code, Section VIII.

Set Pressure (psig)	Orifice Designation and Area (sq.in.)									
	V	W	W <sub>1</sub>	Y	Z	Z <sub>1</sub>	Z <sub>2</sub>	AA	BB	BB <sub>2</sub>
25	32,060	46,164	48,241	62,834	69,112	73,702	82,727	103,879	128,228	140,585
30	35,814	51,570	53,890	70,192	77,205	82,332	92,414	116,043	143,243	157,047
40	44,073	63,462	66,317	86,379	95,009	101,318	113,725	142,804	176,276	193,264
50	52,332	75,354	78,745	102,565	112,813	120,305	135,037	169,565	209,309	229,480
60	60,592	87,247	91,172	118,752	130,617	139,291	156,348	196,325	242,342	265,697
70	68,851	99,139	103,600	134,939	148,422	158,278	177,660	223,086	275,375	301,913
80	77,110	111,032	116,028	151,126	166,226	177,265	198,971	249,846	308,408	338,130
90	85,369	122,924	128,455	167,313	184,030	196,251	220,283	276,607	341,441	374,346
100	93,628	134,817	140,883	183,500	201,834	215,238	241,594	303,368	374,475	410,563
110	101,887	146,709	153,310	199,687	219,638	234,224	262,906	330,128	407,508	446,779
120	110,146	158,602	165,738	215,873	237,442	253,211	284,217	356,889	440,541	482,996
130	118,405	170,494	178,165	232,060	255,247	272,197	305,529	383,650	473,574	519,212
140	126,665	182,387	190,593	248,247	273,051	291,184	326,840	410,410	506,607	555,429
150	134,924	194,279	203,020	264,434	290,855	310,170	348,152	437,171	539,640	591,645
160	143,183	206,172	215,448	280,621	308,659	329,157	369,463	463,932	572,673	627,862
170	151,442	218,064	227,875	296,808	326,463	348,143	390,775	490,692	605,706	664,078
180	159,701	229,956	240,303	312,995	344,267	367,130	412,086	517,453	638,739	700,295
190	167,960	241,849	252,730	329,182	362,072	386,116	433,398	544,213	671,772	736,511
200	176,219	253,741	265,158	345,368	379,876	405,103	454,709	570,974	704,805	772,728
210	184,479	265,634	277,586	361,555	397,680	424,089	476,021	597,735	737,839	808,944
220	192,738	277,526	290,013	377,742	415,484	443,076	497,332	624,495	770,872	845,161
230	200,997	289,419	302,441	393,929	433,288	462,062	518,644	651,256	803,905	881,377
240	209,256	301,311	314,868	410,116	451,093	481,049	539,955	678,017	836,938	917,594
250	217,515	313,204	327,296	426,303	468,897	500,035	561,267	704,777	869,971	953,810
260	225,774	325,096	339,723	442,490	486,701	519,022	582,578	731,538	903,004	990,027
270	234,033	336,989	352,151	458,676	504,505	538,008	603,890	758,299	936,037	1,026,243
280	242,292	348,881	364,578	474,863	522,309	556,995	625,201	785,059	969,070	1,062,460
290	250,552	360,774	377,006	491,050	540,113	575,981	646,513	811,820	1,002,103	1,098,676
300	258,811	372,666	389,433	507,237	557,918	594,968	667,824	838,580	1,035,136	1,134,893

**Notes:**

- For set pressures below 25 psig, consult your sales representative.
- To calculate rated capacities for gas/vapor in lbs/hr. use the following formula:

$W = C * K * A * P * \sqrt{M/T}$

where

W = rated capacity, lbs./hr.

C = Constant for gas or vapor which is the function of the ratio of specific heats,  $k=cp/cv$

K = Coefficient of discharge

A = Nozzle throat (orifice) area, sq. in.

P = Flowing pressure in absolute pressure, psia

M = Molecular weight

T = Absolute temperature at inlet, deg F + 460°F

- To convert capacities in lbs./hr. to SCFM, multiply the capacity by 6.234, then divide by the molecular weight of the gas/vapor.

**Saturated Steam Capacities, USCS Units – Style JB**

**Capacity Formula**

$$W = 51.5 * A * P * K$$

where

W = Rated capacity, lbs./hr.

A = nozzle throat (orifice) area, sq. in.

P = Flowing pressure in absolute pressure, psia: = (Set Pressure x 1.10) + 14.7 or (Set Pressure+ 3) + 14.7, whichever is higher

K = Average coefficient of discharge  
= .856 for V to BB orifice  
= .840 for BB2 orifice

Capacity in pounds per hour of Steam at 10 percent overpressure. Valve discharging to atmospheric pressure. Capacities certified by the National Board of Boiler and Pressure Vessel Inspectors and in accordance with the ASME Boiler and Pressure Vessel Code, Section VIII.

Set Pressure (psig)	Orifice Designation and Area (sq.in.)									
	V 47.85	W 68.90	W <sub>1</sub> 72.00	Y 93.78	Z 103.15	Z <sub>1</sub> 110.00	Z <sub>2</sub> 123.47	AA 155.04	BB 191.38	BB <sub>2</sub> 213.82
25	90,072	129,696	135,531	176,530	194,168	207,062	232,418	291,845	360,251	394,968
30	100,619	144,883	151,402	197,201	216,904	231,308	259,633	326,019	402,435	441,217
40	123,822	178,294	186,316	242,677	266,924	284,650	319,507	401,201	495,239	542,966
50	147,026	211,705	221,231	288,153	316,944	337,992	379,380	476,384	588,044	644,714
60	170,230	245,117	256,145	333,629	366,964	391,333	439,254	551,567	680,849	746,463
70	193,433	278,528	291,060	379,105	416,984	444,675	499,127	626,749	773,654	848,211
80	216,637	311,939	325,974	424,582	467,004	498,016	559,001	701,932	866,458	949,959
90	239,840	345,350	360,889	470,058	517,023	551,358	618,874	777,114	959,263	1,051,708
100	263,044	378,762	395,803	515,534	567,043	604,700	678,748	852,297	1,052,068	1,153,456
110	286,248	412,173	430,718	561,010	617,063	658,041	738,622	927,480	1,144,873	1,255,205
120	309,451	445,584	465,632	606,486	667,083	711,383	798,495	1,002,662	1,237,677	1,356,953
130	332,655	478,996	500,547	651,962	717,103	764,725	858,369	1,077,845	1,330,482	1,458,701
140	355,859	512,407	535,461	697,439	767,123	818,066	918,242	1,153,027	1,423,287	1,560,450
150	379,062	545,818	570,376	742,915	817,143	871,408	978,116	1,228,210	1,516,092	1,662,198
160	402,266	579,229	605,290	788,391	867,163	924,750	1,037,989	1,303,393	1,608,896	1,763,947
170	425,469	612,641	640,205	833,867	917,183	978,091	1,097,863	1,378,575	1,701,701	1,865,695
180	448,673	646,052	675,120	879,343	967,203	1,031,433	1,157,737	1,453,758	1,794,506	1,967,443
190	471,877	679,463	710,034	924,819	1,017,223	1,084,774	1,217,610	1,528,941	1,887,311	2,069,192
200	495,080	712,874	744,949	970,296	1,067,243	1,138,116	1,277,484	1,604,123	1,980,116	2,170,940
210	518,284	746,286	779,863	1,015,772	1,117,262	1,191,458	1,337,357	1,679,306	2,072,920	2,272,688
220	541,487	779,697	814,778	1,061,248	1,167,282	1,244,799	1,397,231	1,754,488	2,165,725	2,374,437
230	564,691	813,108	849,692	1,106,724	1,217,302	1,298,141	1,457,104	1,829,671	2,258,530	2,476,185
240	587,895	846,519	884,607	1,152,200	1,267,322	1,351,483	1,516,978	1,904,854	2,351,335	2,577,934
250	611,098	879,931	919,521	1,197,677	1,317,342	1,404,824	1,576,852	1,980,036	2,444,139	2,679,682
260	634,302	913,342	954,436	1,243,153	1,367,362	1,458,166	1,636,725	2,055,219	2,536,944	2,781,430
270	657,506	946,753	989,350	1,288,629	1,417,382	1,511,508	1,696,599	2,130,401	2,629,749	2,883,179
280	680,709	980,164	1,024,265	1,334,105	1,467,402	1,564,849	1,756,472	2,205,584	2,722,554	2,984,927
290	703,913	1,013,576	1,059,179	1,379,581	1,517,422	1,618,191	1,816,346	2,280,767	2,815,358	3,086,676
300	727,116	1,046,987	1,094,094	1,425,057	1,567,442	1,671,533	1,876,219	2,355,949	2,908,163	3,188,424

**Notes:**

1. For set pressures below 25 psig, consult your sales representative.
2. For superheated steam, multiply the saturated steam capacity by Correction Factor Ksh, found on page 8.

**Superheat Correction Factor -K<sub>sh</sub>**

Flowing* Pressure, psia	Total Temperature Superheated Steam														
	400°F	450°F	500°F	550°F	600°F	650°F	700°F	750°F	800°F	850°F	900°F	950°F	1000°F	1050°F	1100°F
50	.987	.957	.930	.905	.882	.861	.841	.823	.805	.789	.774	.759	.745	.732	.719
100	.998	.963	.935	.909	.885	.864	.843	.825	.807	.790	.775	.760	.746	.733	.720
150	.984	.970	.940	.913	.888	.866	.846	.826	.808	.792	.776	.761	.747	.733	.721
200	.979	.977	.945	.917	.892	.869	.848	.828	.810	.793	.777	.762	.748	.734	.721
250		.972	.951	.921	.895	.871	.850	.830	.812	.794	.778	.763	.749	.735	.722
300		.968	.957	.926	.898	.874	.852	.832	.813	.796	.780	.764	.750	.736	.723
350		.968	.963	.930	.902	.877	.854	.834	.815	.797	.781	.765	.750	.736	.723

\*Flowing pressure is the valve set pressure plus the overpressure plus the atmospheric pressure 14.7 psia [1.014 bara].

**Style JPV-A Pilot Operated Valves**



The Crosby Style JPV-A Valve is a pilot operated valve primarily used for low pressure power or process system overpressure protection where space and weight are primary considerations. Using a basic 300 lb. x 150 lb. ANSI flanged body this design features a pressure loaded main valve with metal seats as the standard. The main valve is actuated by a small spring-loaded pilot valve and shuttle valve assembly. The combination of pilot and shuttle valve assembly provides sharp, rapid operation, and use of a pressure loaded main valve disc in place of a spring loaded disc permits maximum seat load up to the opening point of the valve.

The JPV-A valve meets the requirements of Section VIII of the ASME Boiler and Pressure Vessel Code.

They are available in the sizes shown below and set pressures from 50 psig (minimum) to 300 psig (maximum).

Their capacities are different from those of the Style JB valves and may be calculated using the same formulas with the JPV-A orifice areas listed below and average coefficient of 0.878.

A soft seat design is offered as an option and provides maximum seat tightness up to the opening point of the valve. The soft seat design utilizes a 25 percent glass filled Teflon® O-ring that is rated to a maximum temperature of 500°F. The O-ring seat is designed such that in the unlikely event that the O-ring should fail, the metal seating surfaces would still provide a seal.

Orifice Designation	V	W	Y	Z	Z <sub>2</sub>	AA	BB
Inlet x Outlet (in.)	10 x 14	12 x 16	14 x 18	16 x 18	16 x 20	18 x 24	20 x 24
Actual Area (sq. in.)	44.18	63.62	86.59	95.21	144.04	143.14	176.71



5500 WAYZATA BLVD # 800, MINNEAPOLIS, MN 55416 WWW.PENTAIR.COM/VALVES

All Pentair trademarks and logos are owned by Pentair, Ltd. All other brand or product names trademarks or registered marks of their respective owners. Because we are continuously improving our products and services, Pentair reserves the right to change specifications without prior notice. Pentair is an equal opportunity employer.