



VAREC 7100B SERIES PRESSURE RELIEF VALVE

A weight loaded relief valve that vents to atmosphere and is designed to provide superior seat tightness



FEATURES

- Modular design for flexibility of installation, easy reconfiguration, repair or on-site upgrading.
- Wide range of materials and sizes for service in most applications.
- Oversized port for maximum flow.
- Replaceable 'air cushion' PTFE seating for lowest available leakage for weight-loaded valves (1 SCFH [0.03 Nm³/hr] or less at 90% of setpoint).
- Pallet drip ring and self-draining housing protect the seating surface from condensate and freezing.
- Side and center-guided pallet.
- Hood is easily removed for inspection and maintenance.
- Protective screen prevents entrance of foreign material.
- 'All-weather' non-frosting and ice-resistant coating option available for valve seats and guides.
- Extended service options available for high temperature and chemical applications.

GENERAL APPLICATION

These valves are designed to protect atmospheric and low pressure storage tanks and systems from overpressure. They utilize weights proportional to the seat surface area to achieve the desired setting.

TECHNICAL DATA

Materials: Aluminum, carbon steel, stainless steel
Sizes: NPS 2 - 12 (DN 50 - 300)
Connections: Drilled flange
Pressure settings: To 2 psig (0.14 barg)

VAREC 7100B SERIES PRESSURE RELIEF VALVE

SPECIFICATIONS

Sizes

- 2" (50 mm)
- 3" (80 mm)
- 4" (100 mm)
- 6" (150 mm)
- 8" (200 mm)
- 10" (250 mm)
- 12" (300 mm)

Flanged connections - standard flange drilling

Aluminum

- Drilled to ANSI Class 150 dimensions (flat face)
- Drilled to DIN 2633 (16 bar) dimensions (flat face)
- Drilled to JPI or JIS (flat face) - consult sales

CS, DI and SS body

- Drilled to ANSI Class 150 dimensions (raised or flat face)
- Drilled to imperial DIN 2633 (16 bar) dimensions (raised or flat face)
- Drilled to JPI or JIS (raised or flat face) - consult sales

Testing

Each valve is tested for proper setting and for a leakage rate of 1 SCFH (0.03 Nm³/hr) or less of air at 90% of the set point. Each valve is tested for leak tightness at 75% of set point as required by API standard 2000.

SETTING INFORMATION

Size NPS	Minimum pressure		Low set range	High set range
	Aluminum	316 SS		
2	0.29 oz/in ²	0.70 oz/in ²	Λ 16 oz/in ²	16.01 oz/in ² to 2 psig
3	0.23 oz/in ²	0.55 oz/in ²	Λ 16 oz/in ²	16.01 oz/in ² to 2 psig
4	0.29 oz/in ²	0.60 oz/in ²	Λ 16 oz/in ²	16.01 oz/in ² to 2 psig
6	0.26 oz/in ²	0.61 oz/in ²	Λ 16 oz/in ²	16.01 oz/in ² to 2 psig
8	0.25 oz/in ²	0.55 oz/in ²	Λ 16 oz/in ²	16.01 oz/in ² to 2 psig
10	0.25 oz/in ²	0.63 oz/in ²	Λ 16 oz/in ²	16.01 oz/in ² to 2 psig
12	0.23 oz/in ²	0.59 oz/in ²	Λ 16 oz/in ²	16.01 oz/in ² to 2 psig

1. Minimum set for 10" and 12" 7101B with aluminum trim 0.5 oz/in².
2. Minimum set for 10" and 12" 7101B with stainless steel trim 1.35 oz/in².

MATERIALS

Body	Trim	Insert
Aluminum	Aluminum	PTFE
Carbon steel	316 Stainless steel	NBR
316 Stainless steel		FKM

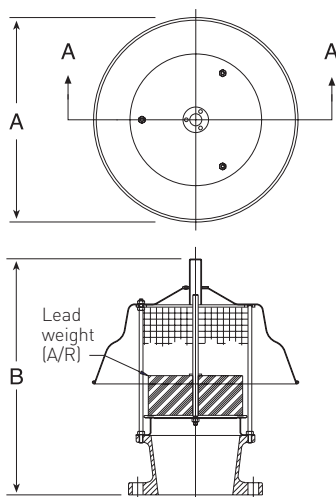

DIMENSIONS, inches (mm)

	Size code					
	2	3	4	6	8	10
	Nominal pipe size					
A	2 (50)	3 (80)	4 (100)	6 (150)	8 (200)	10 (250)
B*	11 (279)	12 ¹¹ / ₁₆ (322)	14 (356)	16 ³ / ₁₆ (411)	18 ¹ / ₈ (460)	24 (610)
B**	13 ⁷ / ₈ (352)	15 ⁵ / ₈ (397)	16 ¹ / ₈ (410)	19 ¹ / ₂ (495)	21 ¹ / ₄ (539)	29 ³ / ₄ (756)

- * Low set
- ** High set

Dimensions are for preliminary general information and should not be used for construction purposes. Certified dimensional drawings are available upon request.

SECTION A - A

VAREC 7100B SERIES PRESSURE RELIEF VALVE

SPECIFICATIONS

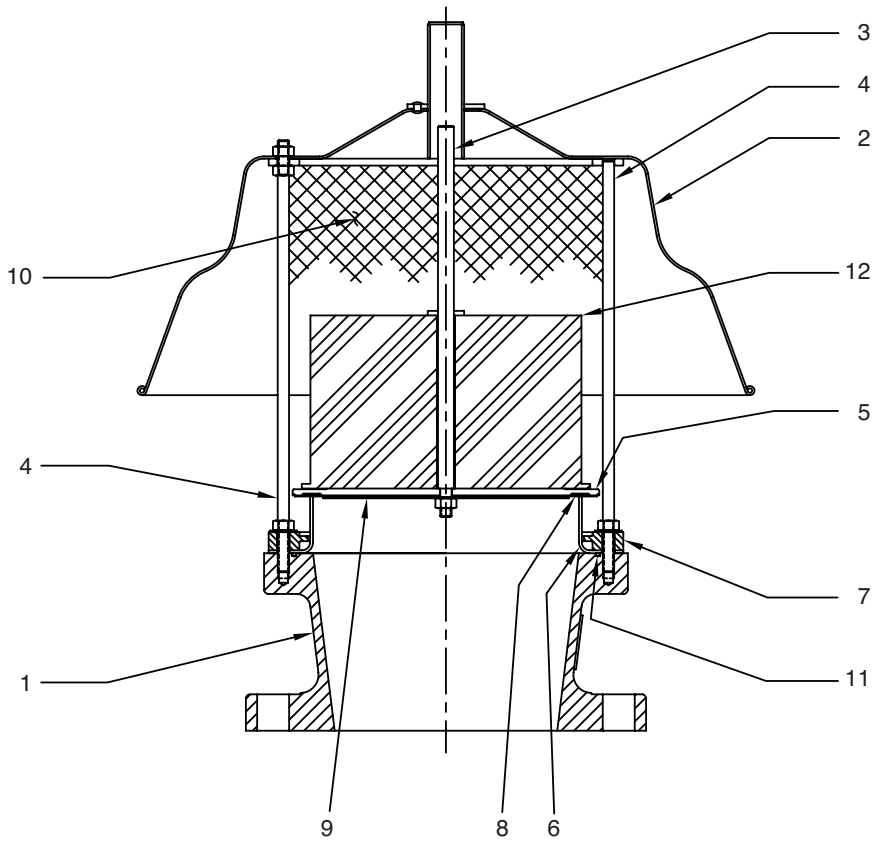

MATERIALS

Item	Material code			
	1	2	3	4
1 Body	Aluminum	Aluminum	Carbon steel	316 SS
2 Weatherhood	Aluminum	Aluminum	Carbon steel	316 SS
3 Guide stem	Aluminum	316 SS	316 SS	316 SS
4 Guide posts	316 SS	316 SS	316 SS	316 SS
5 Pallet	Aluminum	316 SS	316 SS	316 SS
6 Seat ring	Aluminum	316 SS	316 SS	316 SS
7 Seat ring retainer ⁽¹⁾	Polypropylene	Polypropylene	Polypropylene	Polypropylene
8 Insert ⁽¹⁾	PTFE	PTFE	PTFE	PTFE
9 Insert retainer	Aluminum	316 SS	316 SS	316 SS
10 Screen ⁽¹⁾	HDPE	HDPE	HDPE	HDPE
11 O-ring ⁽¹⁾	NBR	NBR	NBR	NBR
12 Weights	Lead	Lead	Lead	Lead

NOTES

1. Materials are as standard. Refer to page 8 for other materials and their corresponding temperature ranges.
2. PTFE coated aluminum may be supplied with material codes 2 - 5 to achieve lower settings.
3. All nuts and cap screws are 316 SS.

VAREC 7100B SERIES PRESSURE RELIEF VALVE

FLOW CURVES

7100B SERIES RELIEF VALVE, SET AT 0.865 INCH OF WATER

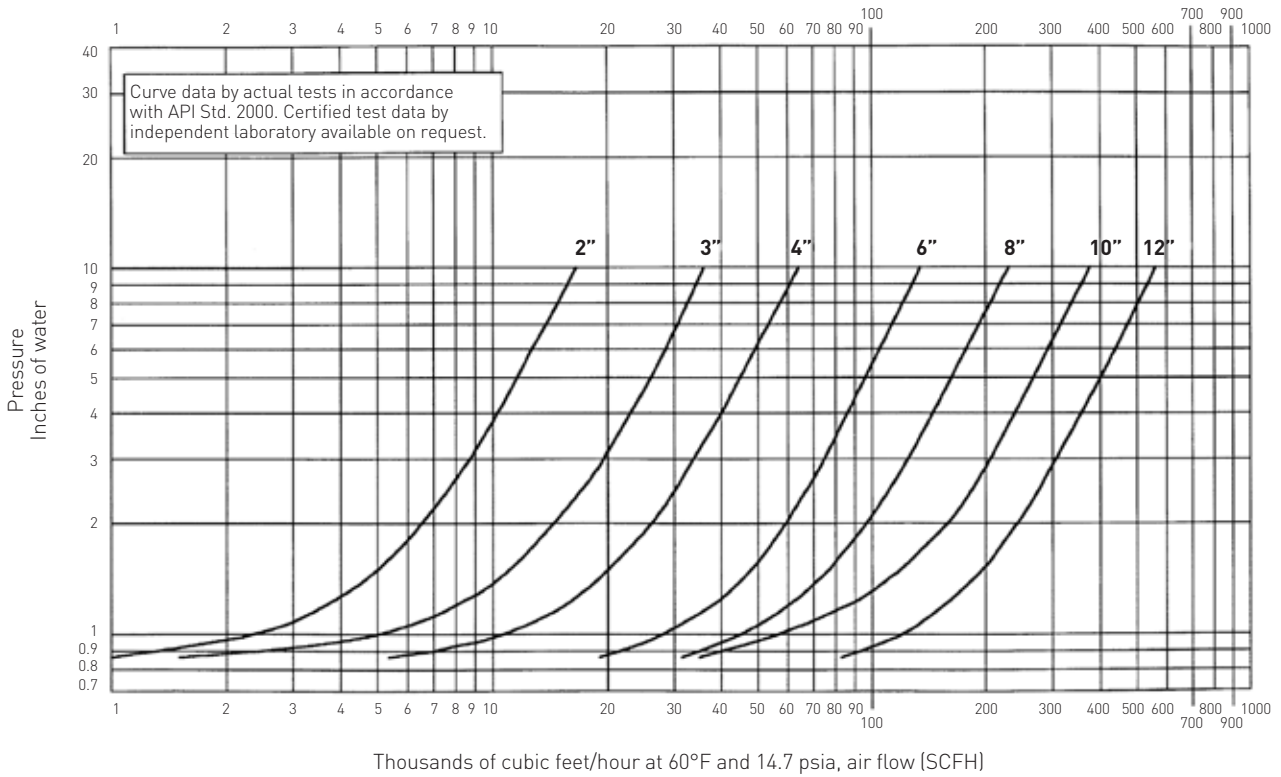

7100B SERIES RELIEF VALVE, SET AT 1 INCH OF WATER

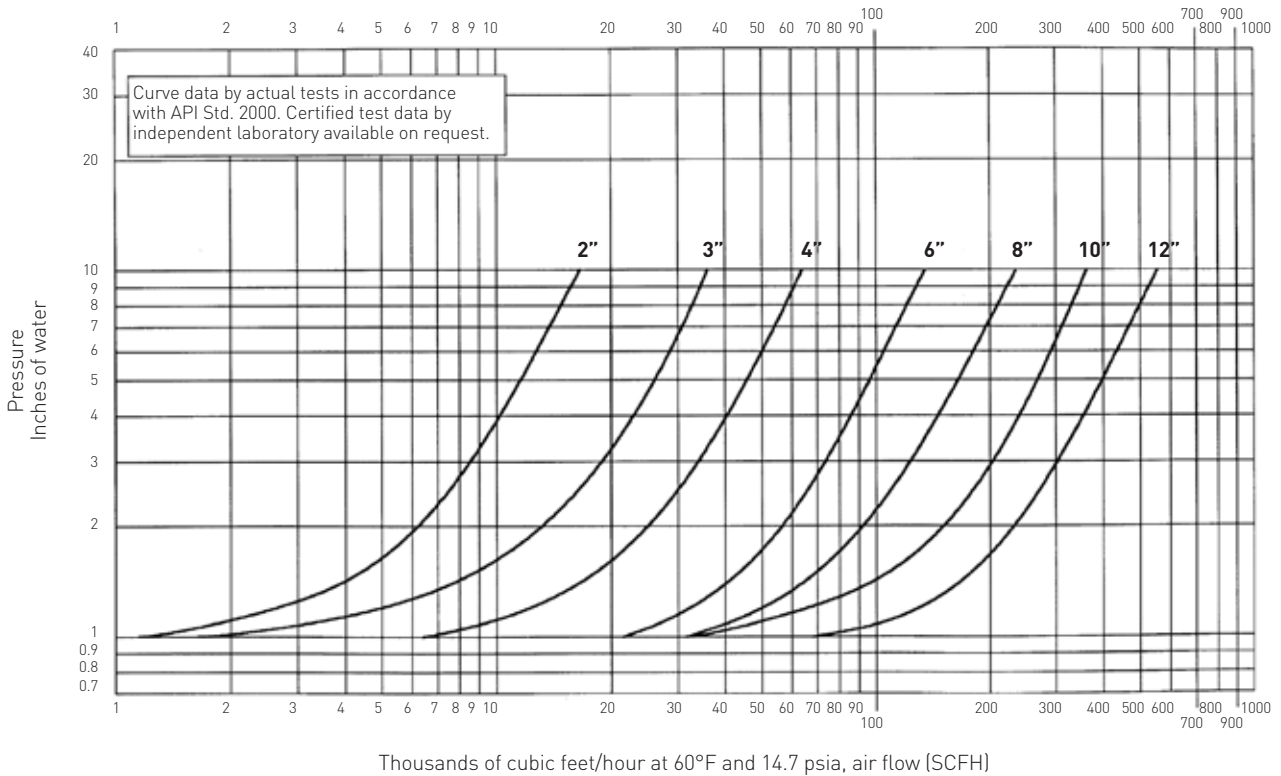

VAREC 7100B SERIES PRESSURE RELIEF VALVE

FLOW CURVES

7100B SERIES RELIEF VALVE, SET AT 2 INCHES OF WATER

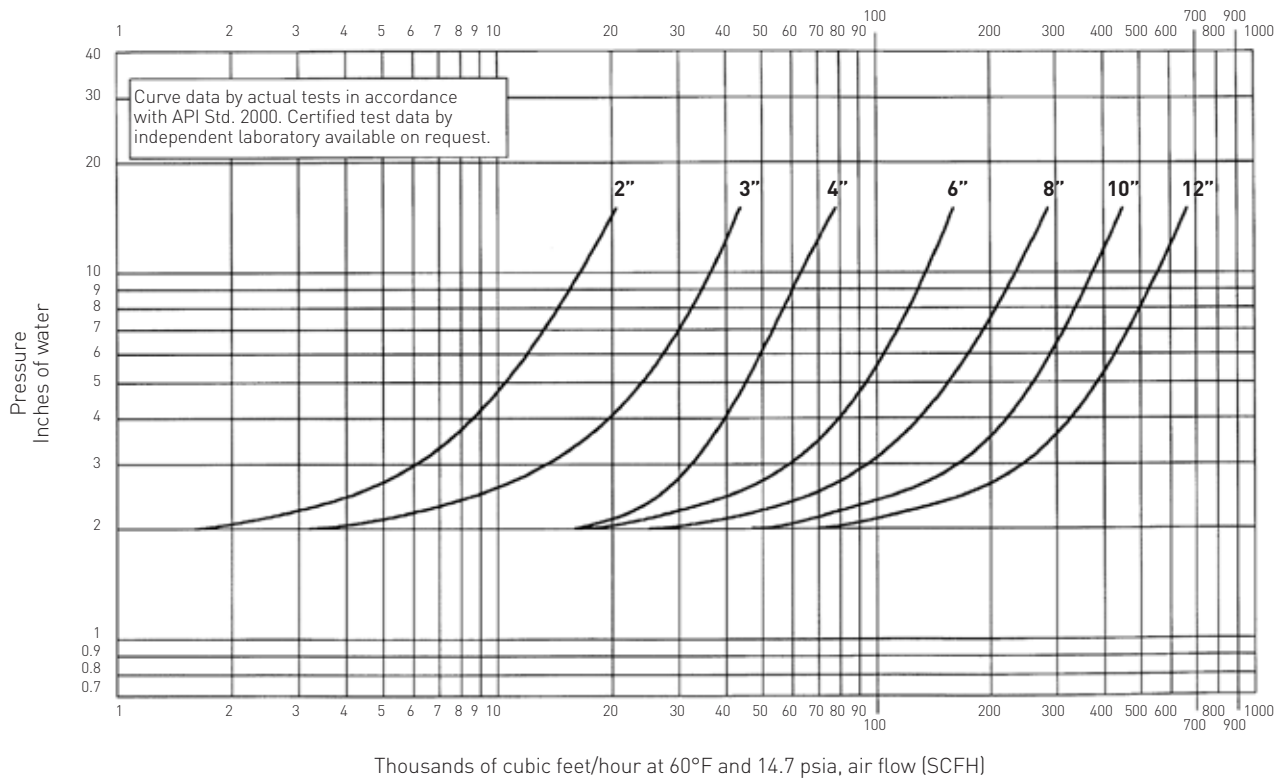

7100B SERIES RELIEF VALVE, SET AT 4 INCHES OF WATER

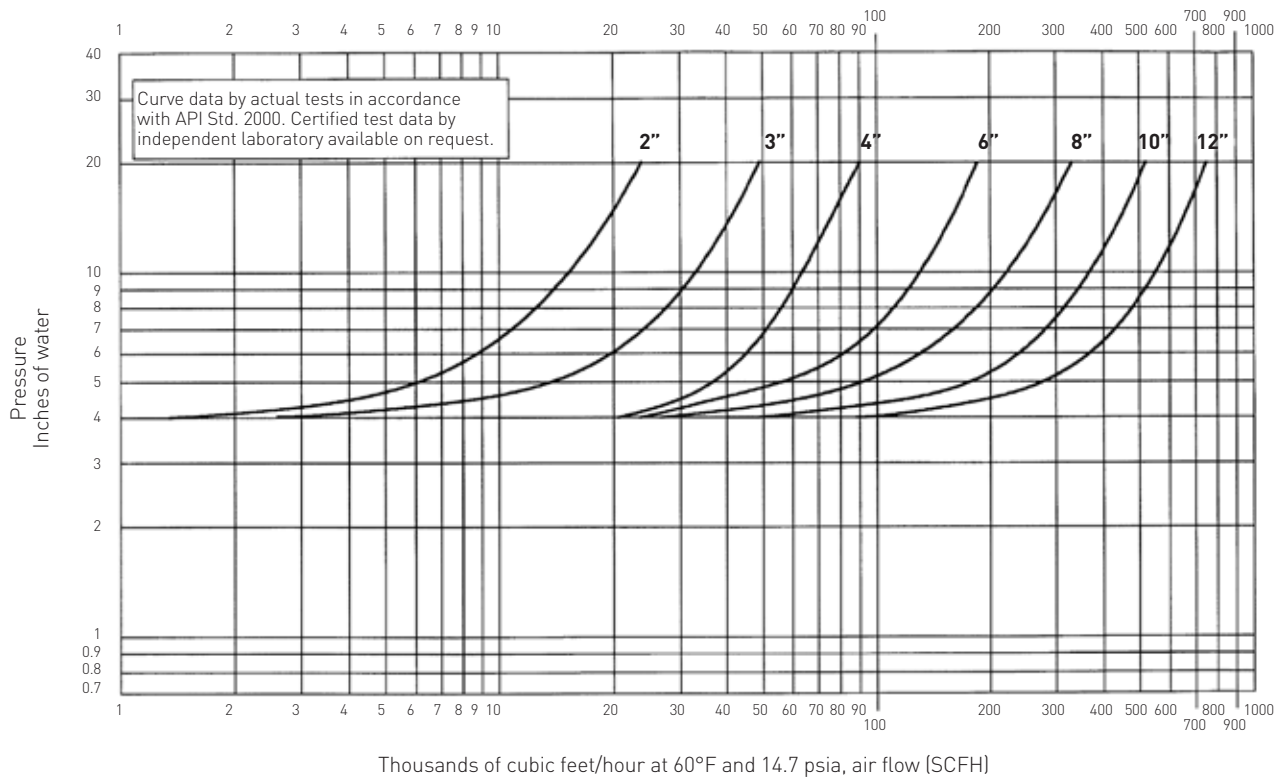

VAREC 7100B SERIES PRESSURE RELIEF VALVE

FLOW CURVES

7100B SERIES RELIEF VALVE, SET AT 6 INCHES OF WATER

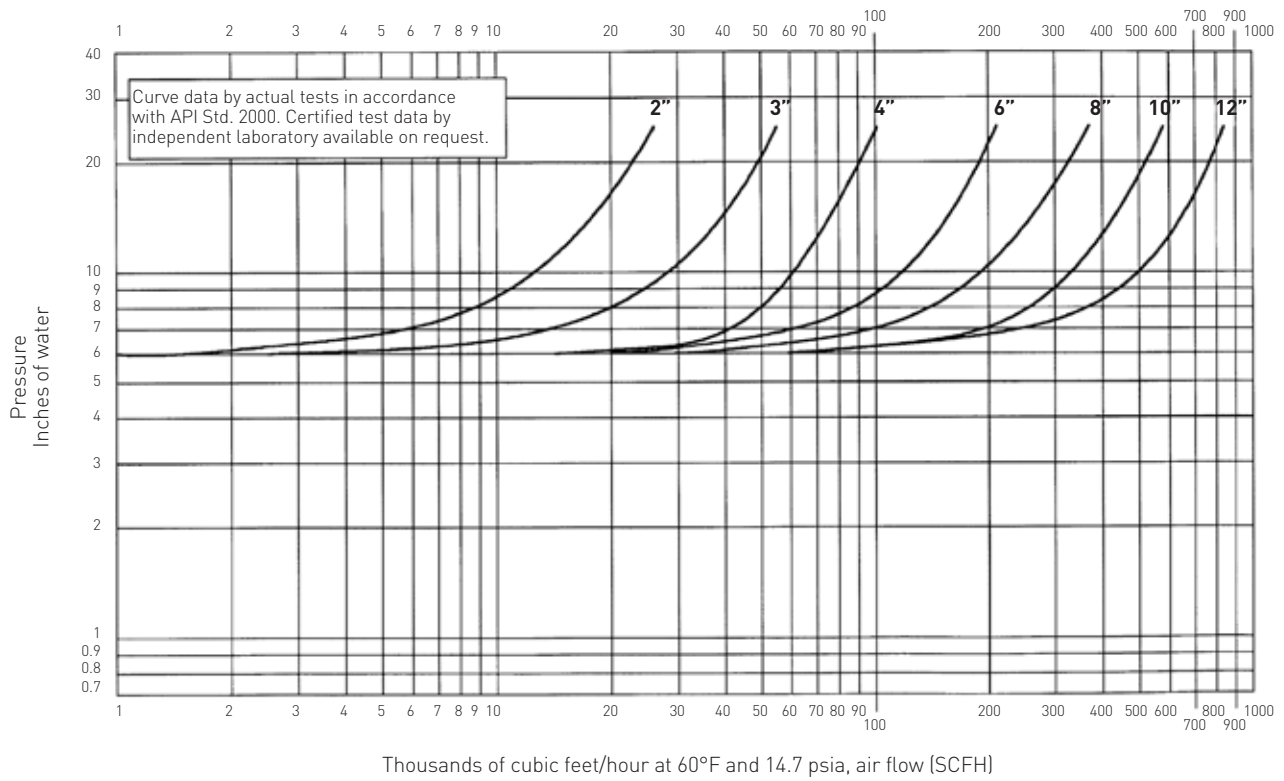

7100B SERIES RELIEF VALVE, SET AT 8 INCHES OF WATER

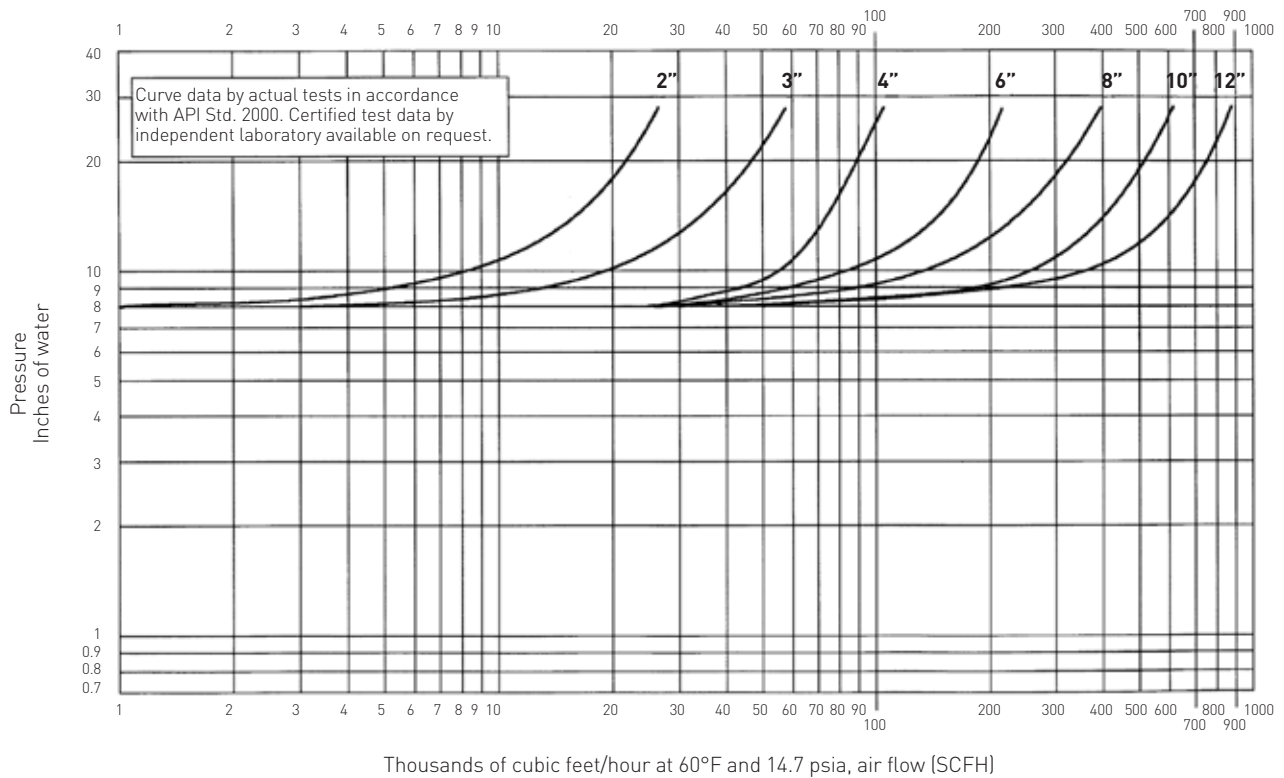

VAREC 7100B SERIES PRESSURE RELIEF VALVE

FLOW CURVES

7100B SERIES RELIEF VALVE, SET AT 10 INCHES OF WATER

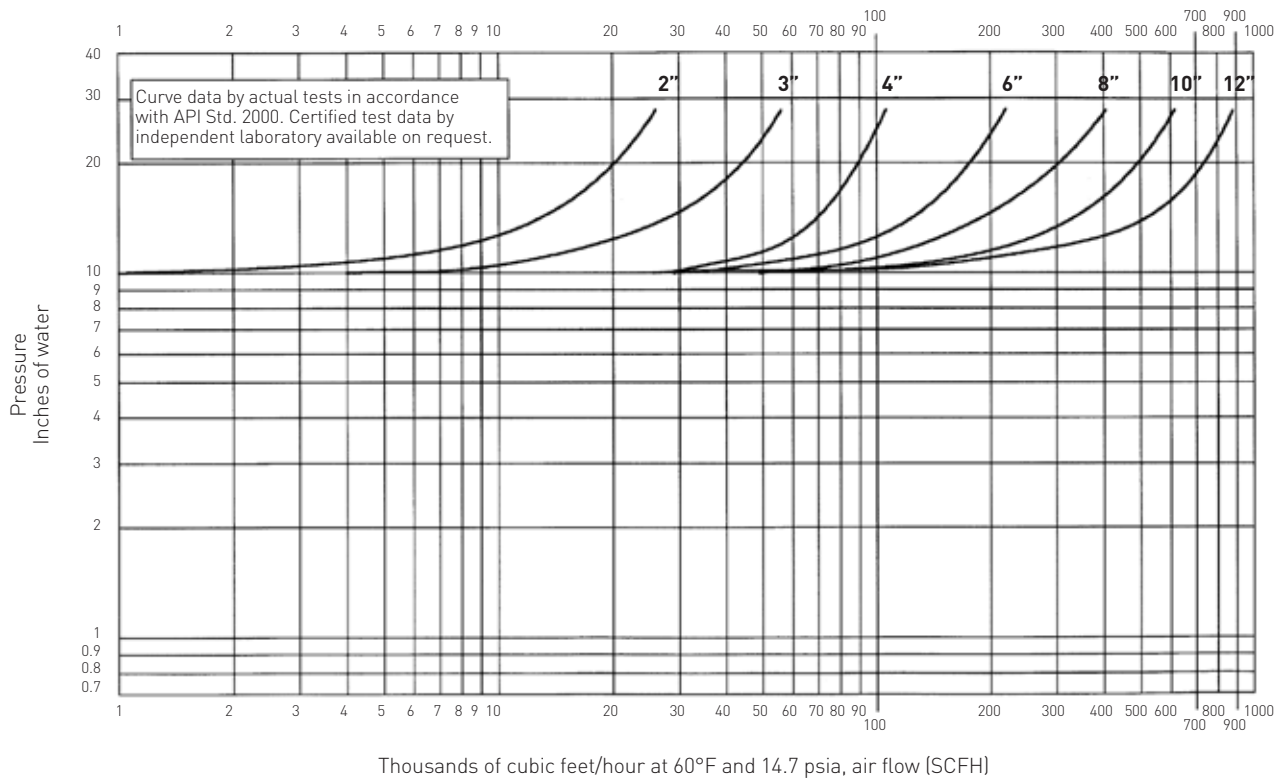

VAREC 7100B SERIES PRESSURE RELIEF VALVE

SELECTION GUIDE

Example:	710	0B	2	1	T	FF	OP	02
Model								
710	Air cushion pressure relief valve							
Configuration								
0B	Standard							
1B	All weather type (25°F to 200°F)							
Size								
2	2"							
3	3"							
4	4"							
6	6"							
8	8"							
0	10"							
1	12"							
Body/trim material								
1	Aluminum/aluminum (-65°F to 250°F)							
2	Aluminum/316 stainless steel (-65°F to 250°F)							
3	Carbon steel/316 stainless steel (-20°F to 350°F)							
4	316 stainless steel/316 stainless steel (-65°F to 350°F)							
Insert material								
T	PTFE (-65°F to 400°F)							
B	NBR (-40°F to 250°F)							
V	FKM (-15°F to 400°F)							
Flange connection								
FF	Flat face flange drilled to ANSI 150 with fractional studs							
FR	Raised face flange drilled to ANSI 150 with fractional studs (not available on aluminum)							
DF	DIN flat face flange drilling							
DR	DIN raised face flange drilling (not available on aluminum)							
Gasket/O-ring and retainer/screen material								
OP	Standard (fiber/NBR) and plastic (-40°F to 250°F)							
OS	Standard (fiber/NBR) and stainless steel (-40°F to 250°F)							
TP	PTFE and plastic (-65°F to 250°F)							
TS	PTFE and stainless steel (-65°F to 350°F)							
BP	NBR and plastic (-40°F to 250°F)							
BS	NBR and stainless steel (-40°F to 250°F)							
VP	FKM and plastic (-15°F to 250°F)							
VS	FKM and stainless steel (-15°F to 350°F)							
Setting range (see table, page 2)								
02	Low setting							
04	High setting							

Example: 2" pressure relief valve, aluminum body with aluminum trim, PTFE insert, flat faced flange, standard fiber/NBR gaskets, low pressure set range, temperature range: -40°F to 250°F